

USER MANUAL

uFlamer

V2.0

2020.2



★ Please read this manual carefully before operating this product.

★ Warranty card attached in the manual, please keep it well.

▲Warning

- Unauthorized repair are prohibited, it may cause serious incident.
- Make sure power supply in consistent with the rated voltage of the equipment, and the socket must well grounded. Unplug and turn off the machine when not use.
- Before connect the power cable, communication DMX cable should well connected and ensure the command keep at firing OFF status. And safety lock stay at test mode.
- The device can only be placed horizontally. Safety distances are marked on the device (at least 15m in projection direction, at least 5m around the device).
- After turning on the device, no person allows to stay in the danger area. Ensure all persons that are part of the show be informed about the safety distance, risks and functions of the device.
- Always have a CO2 fire extinguisher and an extinguishing blanket in case of needed.
- If there be any doubt as to the safety operation of the device in any circumstances, the device should be taken out of service immediately. Be sure the device is in good operating condition before use. If fail to fire correctly, immediately shut down and check it accordingly
- Be sure to use high quality flame fluid, otherwise, it is easily lead to failure or danger. Be careful when refill the flame fluid tank. Please keep flame fluid away from heat source, sparks, fire or other possibility of ignition. Do not smoke!
- The operator responsible for the control of uFlamer must always have a clear view of the device, so that he/she can stop the show immediately when there is danger. The main AC power switch should near operator. So that operator can turn off the power of all devices in case of abnormal.
- The device shall not be altered and applied to other use purpose.

▲Foreword

Thanks for choosing uFlamer. Please read following manual carefully and completely before operating this product. Operate according to instructions is very important for safety, and can elongate the service life of the machine.

Strictly follow the instruction in the manual when operate uFlamer. If you have any doubts, please contact SHOWVEN technologies Co., Ltd by info@showven.cn.

We assume the person who use or come in contact with the device are familiar with how the device should be handled. This includes proper use, maintenance and repair of the machine as defined in this user manual.

Disclaimers:

SHOWVEN technologies Co., Ltd excludes liability for unsafe situations, accidents and damages resulting from:

1. Ignoring warnings or regulations as shown on flamer or this manual.
2. Use for other applications or circumstances other than those indicated herein.
3. Changes to the flamer, including use of non-original spare parts.
4. Removed safety cover without authorization from SHOWVEN.
5. Use this machine by unqualified or untrained personnel.
6. Improper use of machine.

▲ Technical Specifications

MODEL	uFlamer
Dimension (L x W x H)	330 x 260 x 320mm
Input	AC 100-240V, 50-60Hz
Work power	300W
Interface	Double DMX Interface;
Control	Standard DMX
Effect Maximum Height	8-10m (no wind)
Fuel	ISOPROPANOL ISOPAR G,H,L,M
Fuel Bottle Capacity	5L
Weight (no fuel)	14KG
Fuel Consumption Rate	60ml/s

▲ Structure of uFlamer

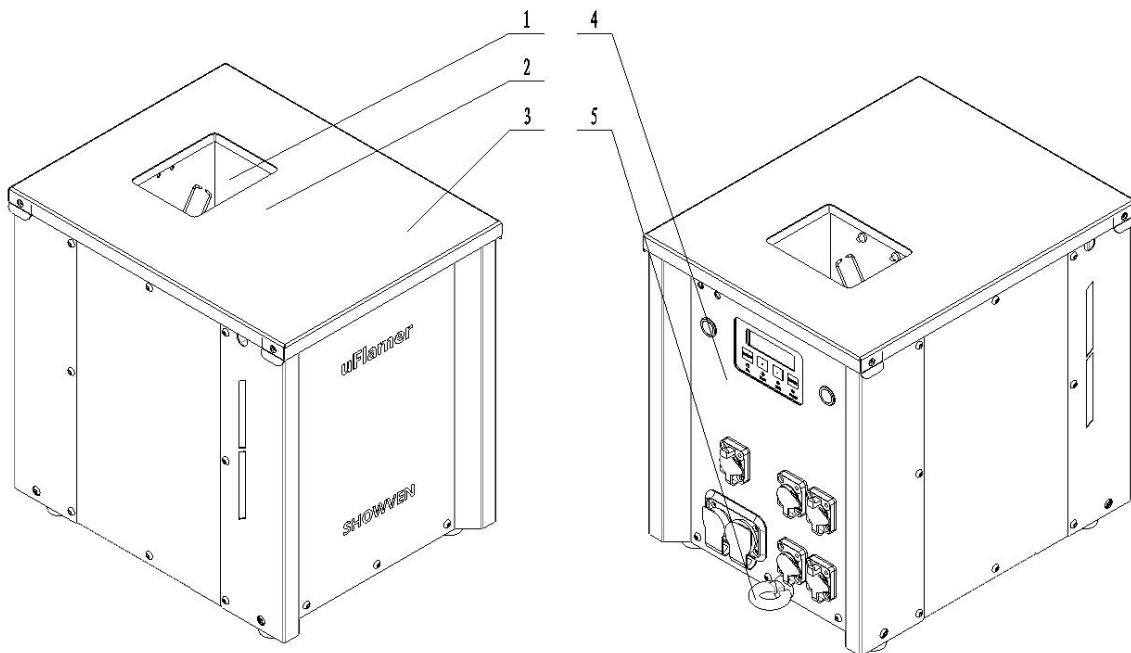

1. Firing Box
2. Top Panel
3. Fuel Bottle Area
4. Control Panel
5. Safety Loop

▲ Overview of Bottom Panel

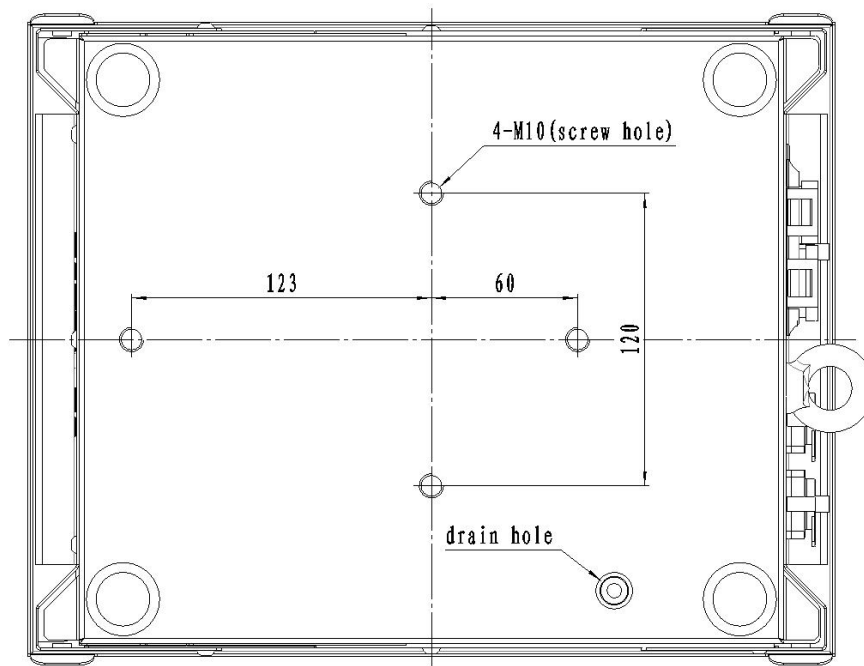

▲ Overview of Control Panel

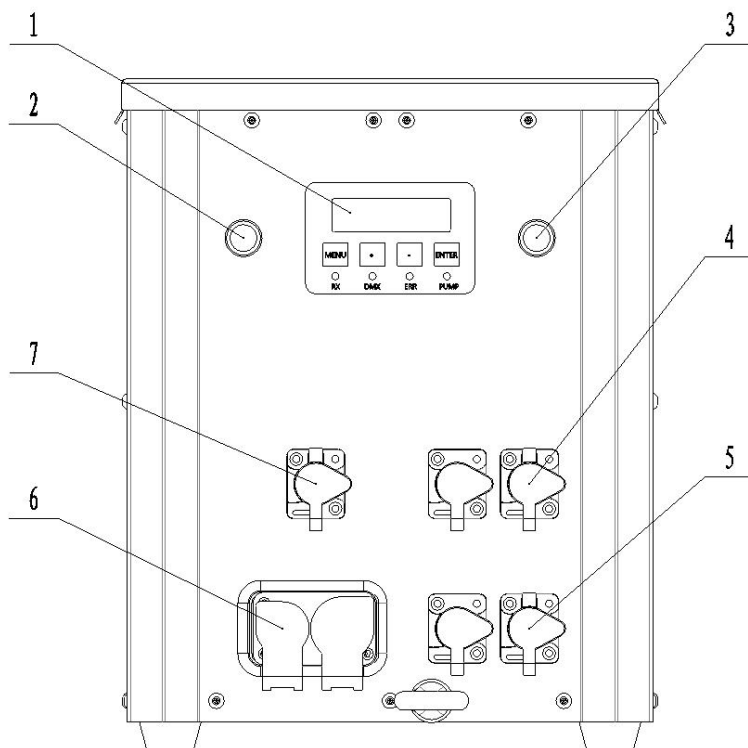

1. LCD screen operate panel
2. ON/OFF switch
3. Safety Lock
4. 3-pin DMX socket
5. 5-pin DMX socket (Wireless DMX512 power DC5V between 1 and 4 pin)
6. 110V/220V Power socket C
7. Input Charging

▲ Operation Panel

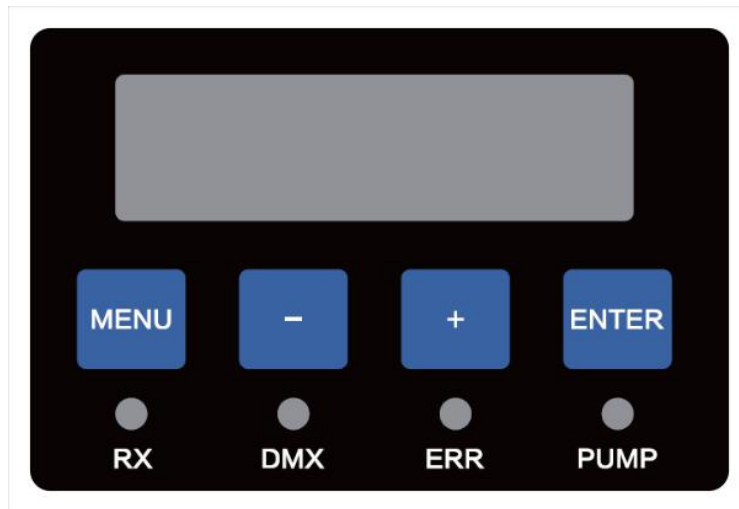

1. LED Display Area

- RX : Radio receiving (reserved)
- DMX : DMX signal. Flash means DMX signal available, otherwise no DMX signal
- ERR : Light on when there is an error
- PUMP : Light on when pump is running

2. Button Functions:

- MENU : Switch interface to setup parameter;
 - + : Parameter Up
 - : Parameter Down
 - ENTER : Confirm and save parameters (screen will flash when parameters saved)
- Note: screen display will switch to main interface if don't press button for a long time.*

3. Welcome Interface

- First Line:** Product model and software version
- Second Line:** Equipment series number

uFlamer191129
X-F1190006

4. Main Interface

- First Line:** Fire address or Safe address ;
DMX ChannelMode(**2CH-P** / 6CH / 2CH-N)
- Second Line:** Pressure100 (e.g. 100=10bar); V: 13.6 means internal voltage is 13.6V.

Fire 1 M:2CH-P
P: 100 V: 13.6

Safe 2 M:2CH-P
P: 100 V: 13.6

5. Alert Message

Alert Message		Explanation
E0	Test Mode	Safety lock located at TEST MODE
	Factory Mode	DMX signal blocked in factory mode
E1 Pressure Err		Pressuriser for about 13s, pressure value failed to reach 100%, system will report E1. Possible fault: No fuel, pump failure, pipeline problem etc.
E2 P Relief Err		Pipeline can't release pressure leads to pressure relief error. Possible fault: pressure release valve failure, pipeline problem or control system problem etc.
E5 Voltage Err		Battery voltage >18V or <9V for continuous 5s, machine stops running Possible fault: the battery is low
E6 Tip Err		if the machine slant over 45°, it stops running, system will report E6

6. Interface setup

Press "MENU" to switch through setup menu

DMX ChannelMode	Menu	Range	Explanation
6CH / 2CH-N	Set DMX Address	1~512	DMX address setup
2CH-P	Fire Address	1~512	Fire address setup
	Safety Address	1~512	Safety address setup

7. Advanced Interface

Press "MENU" 3s enter advanced interface, press "MENU" to switch interface, press "MENU" 3s can back to main interface.

Items	Contents	Description
Drive Test	OFF / Pump / Igniter / Relief Valve / Jet Valve	
	1. Pump	Pump running 1s, if pressure reached the target value, the pump will not running.
	2. Igniter	Ignite 1s
	3. Relief Valve	Release valve will be on and off for 3 times
	4. Jet Valve 1	Safety lock located at user mode, release pressure for 5s, jet valve will be on and off for 3 times
	5. Jet Valve 2	
语言 (Language)	English / Chinese	Language switch
Mode Select	Normal Mode / Factory Mode	Factory mode is for test in factory only
Tip setting	OFF / ON	Turn ON or OFF When turning on, if the machine slant over 45°, the flamer stops running, system will report E6
DMX ChannelMode	2CH-P / 6CH / 2CH-N	Change the DMX ChannelMode.
DefaultParameter	OFF / ON	Reset default parameter settings

▲ Operation Instructions

1. Direction explanation

Please read the safety instructions printed on the top panel of uFlamer carefully.

Safety distances for uFlamer **is at least 15m in projection directions and 5m around.**



Never point the flamer on humans, animals, fire hazardous substances or other sensitive items.
 Always disconnect the power supply before any physical contact with the flamer.
 Never store the flamer under pressure.
 Always contact SHOWVEN if necessary.

uFlamer		SHOWVEN®	
AC 100V-240V 50/60Hz	300W		
Showven Technologies Co.,Ltd. www.showven.cn info@showven.cn +86-731-83833068 Building B1, Changsha E Center, Liuyang Economic Development Zone, Hunan, China.		 MADE IN CHINA	
	WARNING Hazardous voltage inside, please do not remove the cover unless by trained personnel.	Serial Number  9 788087 049099	
	People and flammable materials should keep a minimum safety distance of 5m from the flamer.		

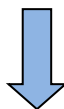



People and flammable materials should keep a minimum safety distance of 5m from the flamer.





2. DMX ChannelMode selection for host controller ZK6200/ZK6300





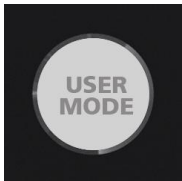
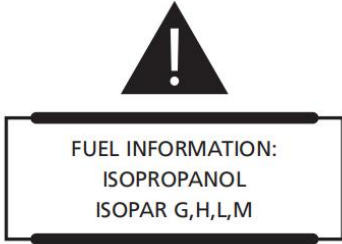

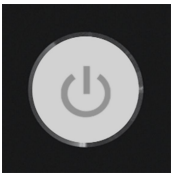
DMX ChannelMode	Host controller device selection	Host controller ZK6200/ZK6300 device setting	Note
2CH-P mode	--none--	Press F3 --Select device items-- Confirm	--
▲ 6CH mode	FLAMER		Feedback the pressure value
2CH-N mode	SPARKULAR		Feedback the pressure value

▲ 6CH mode is recommended, when you use host controller ZK6200/ZK6300 for the show control.

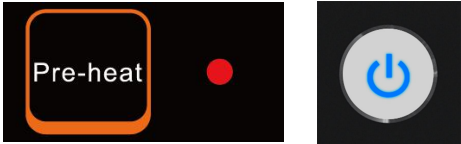
3. Quick Operation Sheet for reference (Specialized for host controller ZK6200/ZK6300)

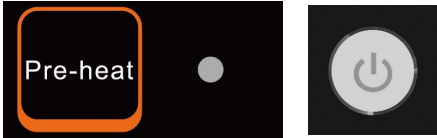
Immediately upon receiving the machine, carefully unpack the carton, check the machine received in good condition. Ensure safety operation of machine, please do following below operation procedures when operate uFlamer.

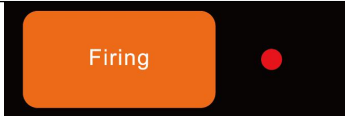
Operation step	Schematic diagram and explanation	Explanation
1. Installation	The device can only be placed horizontally, if placed on truss, please locked with extra safety ropes.	
2. Locate safety lock at TEST MODE	 <p>Press the button off, The LED is off.</p>	<p>Before operate machine please locate safety lock at TEST MODE.</p> <p>TEST MODE: operator can test the ignition of the flamer, but the fuel ejection function disabled, so there is no fuel eject.</p> <p>USER MODE: the device can generate flames normally. Please strictly follow the safety distance requirement, remove all human, animal or flammable objects in the danger area.</p>
3. Fueling		Please fueling with high quality fuel according to requirement of this manual
4. Power and DMX cable connection		
5. Switch ON the machine	 <p>Press the button on.</p>	Please confirm safety lock located at TEST MODE before switch on the POWER ON/OFF.
6. Set DMX address		

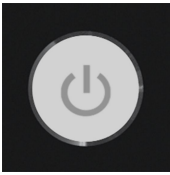
7. Compression	 <p>The blue LED shows the pressure is ready.</p>	Host controller: Press “pre-heat” button (both of the lights on)
8. Check device status in TEST MODE	 <p>The LED is off.</p>	Reconfirm safety lock located at TEST MODE before test. In this status, the igniter will activated, but there is no flame.
9. Pressure Relief		Host controller: Press “pre-heat” key (both of the lights off)
10. Press the safety lock to USER MODE	 <p>Press the button on, The LED is on.</p>	Before switch to USER MODE, Please strictly follow the safety distance requirement, remove all human, animal or flammable objects in the danger area.
11. Compression		Host controller: Press “pre-heat” button (both of the lights on)
12. Firing		Host controller: Press “FIRING” key
13. Pressure Relief		Relief pressure when shows finished or uFlamer not use for a long period. Host controller: Press “pre-heat” key (both of the lights off)
14. Switch safety lock to TEST MODE	 <p>Press the button off, The LED is off.</p>	Guarantee safety use for next time
15. Power off	 <p>Press the button off.</p>	Power off uFlamer, tear down power cable and DMX cable, pack up the device when it is cooled down.

4. SHOWVEN host controller ZK6200/ZK6300

1) Technical Specifications

Host controller model: ZK6200	
	Parameters:
	Dimension: 390×300×110mm
	Weight: 3.5kg
	Input: 110-240Vac, 50/60Hz
	Work power: 15w
	Work Temp.: -10℃ ~ 50 ℃
	Interface: 2*CAN port, 2* media port (music trigger), 2*MIDI port (music trigger), 1* DMX512 input, 1*DMX512 output.
	Support Max. 200m communication cable
	3350 mAH Li-battery (5h battery life when fully charged)

- Standard DMX512 signal output.
- Support 18units(ZK6200) or 54units(ZK6300) at the same time.
- 5 standard dynamic modes: Synchronization, Center to Ends, Ends to Center, Left to Right, Right to Left. And an user definable Special Effect mode, support 8 files, each file support 36000 lines maximum (effects lasts for 30min).
- Multi trigger sources: manual, music or midi input.
- RDMX monitoring function: system can send back flamer working status info such as pressure, warming etc. and display on the screen.
- Emergency stop function.

2) Operational Panel



- Cable Connection Area
 AC Input: AC Power Input
 CAN: CAN communication input/output
 MIDI In: Midi time synchronous signal input
 DMX 512: DMX signal input/output
 LAN: network interface
 USB: program download interface, SparkularEdit200 software port

b) Manual firing operation region



c) Mode Selection Area



There are 5 standard dynamic mode and 1 special effects mode. Each mode support 8 files, it can be switched easily on the mode selection area.

d) LCD display Area

F1: Main menu

F2: File selection

F3: Configuration

F4: About host controller

e) Edit/Control Area



3) Set uFlamer DMX address (e.g. 6CH mode)

FLAMER No.	DMX address
1	1
2	7
3	13
4	19
5	25
6	31
7	37
8	43
9	49
10	55
11	61
12	67
13	73
14	79
15	85
16	91
17	97
18	103

Note: wrong DMX address setup may leads to flamer out of control.

4) Host controller ZK6200 operation

- Press "F3" enter host controller configuration menu, DEVICE choose "CIRCLE FLAMER" as below.
- Set Start No. and End No. of device.

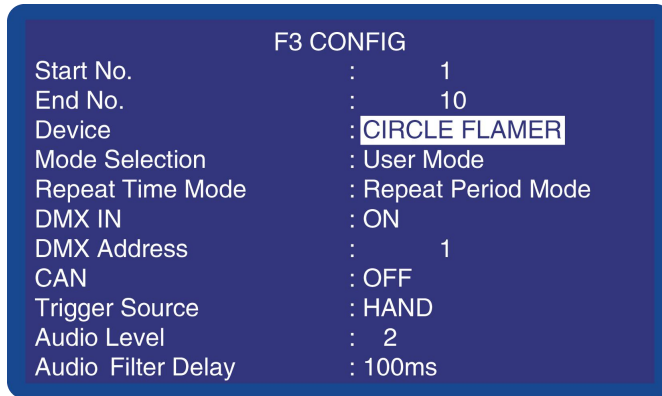

- Press "F1" back to main interface.

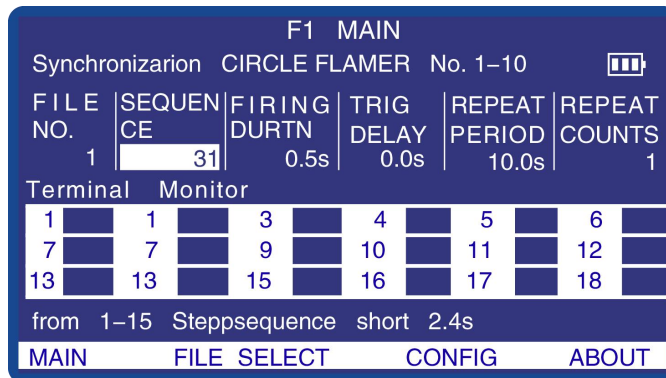

- Set the FIRING DURTN, REPEAT PERIOD and REPEAT COUNTS values. (ignore SEQUENCE setting on uFlamer)
- Press "Pre-heat" to activate the compression of device.
- Press the "Firing" to make a show.

Note: Put safety lock at "TEST MODE" to check the signal connection and nozzle status before use the device for firing. For Emergency stop, press "PRE-HEAT", device will enter pressure relief mode, and stop emergently.

5. DMX CONTROL (2CH-P)

Channel	Function
CH-F	Ignition ON/OFF: (0~110) Ignition OFF, (111~255) Ignition ON. The default value F=1
CH-S	Mode setup: (0~49) Pressure Relief Mode (Emergency Stop), (50~200) Compression Mode, (201~255) Pressure Relief Mode (Emergency Stop). The default value S=2

Note: F = Fire Address ; S = Safety Address.

6. DMX CONTROL (6CH)

Channel	Function
CH-1	--none--
CH-2	--none--
CH-3	Ignition ON/OFF: (0~253) Ignition OFF, (254~255) Ignition ON
CH-4	Firing Duration setup: 0 and 255 is permanent fire (8s is limit duration time); 1~254 is 10~2540ms duration time (Manual firing duration = DMX Value * 10ms)
CH-5	--none--
CH-6	Mode setup: (0~49) Pressure Relief Mode (Emergency Stop), (50~200) Compression Mode, (201~255) Pressure Relief Mode (Emergency Stop)

7. DMX CONTROL (2CH-N)

Channel	Function
CH-1	Ignition ON/OFF: (0~110) Ignition OFF, (111~255) Ignition ON
CH-2	Mode setup: (0~49) Pressure Relief Mode (Emergency Stop), (240~255) Compression Mode,

▲ Battery and Maintenance

1. Battery Recommendation



Standard	5200mah 35c-70c
Voltage	14.8V
Size	140*43*44mm
Charge Jack	2.54-5A
Discharge Jack	XT60
Installation	Contact our sales for the video

2. Maintenance

1. To maintain the system in good performance and running status, it is recommended to running the device at least once per month.
2. Maintenance of the nozzle: Nozzle need to be cleaned up , and it is recommended that once every six months (depending on the environment and frequency of use). In the process of using the equipment, if the flame shape is seriously deformed or the fuel injection line is significantly deformed or coarsened, the nozzle should be removed immediately for cleaning.
3. Maintenance of the O-ring: If it is found that the O-ring of the nozzle is damaged or ageing when cleaning the nozzle, the O-ring should be replaced in time (material and size of O-ring: fluororubber O-ring, the outermost diameter is 14 mm, and the line diameter is 2 mm).

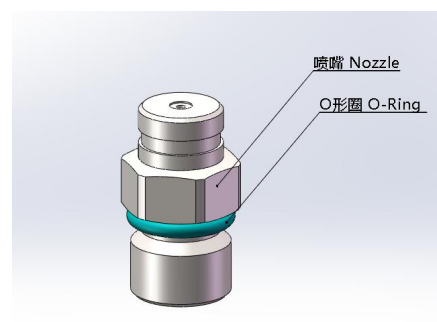

Warranty Instructions

▲Sincere thanks for your choosing our product, you will receive quality service from us.

▲The product warranty period is one year. If there are any quality problems within 7 days after shipping out from our factory, we can exchange a brand new same model machine for you.

▲We will offer free of charge maintenance service for machines which with hardware malfunction (except for the instrument damage caused by human factors)in warranty period. Please don't repair machine without factory permission.

★Below situations NOT included in warranty service:

- 1.Damage caused by improper transportation, usage, management, and maintenance, or damage caused by human factors;
- 2.Disassemble, modify or repair products without Showven's permission;
- 3.Damage caused by external reasons (lightning strike, power supply etc)
- 4.Damage caused by improper installation or use;

For product damage not included in warranty range, we can provide paid service.

★Invoice and warranty card are necessary when applying for maintenance service from SHOWVEN.

Warranty Card

Product Name:		Serial No.	
Purchase Date:			
Tel:			
Address:			
Info.feedback about the problem			
Actual problem:			
Maintenance detail:			
Service Engineer:		Service Date:	

SHOWVEN®



Showven Technologies Co., Ltd.

Add: Building B1, Changsha E Center No.18, Xiangtai Road, Liuyang Economic Development Zone, Changsha City, 410300, Hunan Province, P.R.China.

Tel: +86-731-83833068

Web: www.showven.cn

E-mail: info@showven.cn